

2R100ER

Broyeur déchiqueteur industriel
Industrial shredders



2 arbres / Commande électrique

2 shaft / Electric drive

75 kW

ISIGRANTech

Partenaire intégrateur pour la France

SatrindTech
Shredding Solutions

2R100ER

Made in Italy 

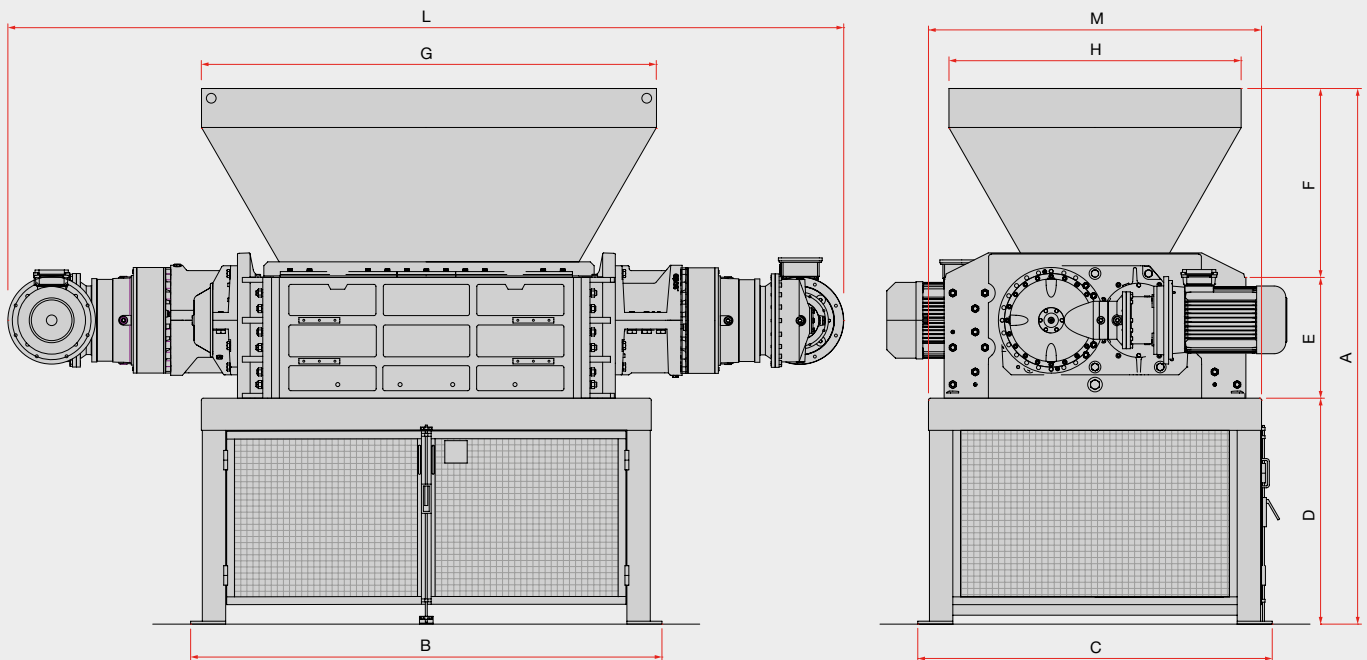

Dimensions - Dimensions

Modèle Model	A mm	B mm	C mm	D mm	E mm	F mm	G mm	H mm	L mm	M mm
2R15/100ER	2750	2420	1820	1160	620	970	2340	1500	4295	1710
2R20/100ER	2750	2870	1820	1160	620	970	2790	1500	4745	1710

Données techniques - Technical data

Modèle Model	Chambre de broyage Shredding chamber	Epaisseur des lames Blades thickness	Puissance Power	Poids Weight
2R15/100ER	1510x1100 mm	50 - 75 mm	75 (45+30) kW	11950 kg
2R20/100ER	1960x1100 mm	50 - 75 mm	75 (45+30) kW	14150 kg

Applications - Applications

	Plastique Plastics	3-5
	Tambours en plastique (200-220 L) Plastic drums (200-220 L)	80-130 pcs/h
	Déchets urbains solides Municipal solid waste	5-10
	Tambours métalliques Metal drums	80-130 pcs/h
	Filtres à huile Oil filters	2-3
Matériaux - Material		t/h