

2R50ER

Broyeur déchiqueteur industriel
Industrial shredders



2 arbres / Commande électrique

2 shaft / Electric drive

37 kW

ISIGRANTech

Partenaire intégrateur pour la France

SatrindTech
Shredding Solutions

2R50ER

Made in Italy 

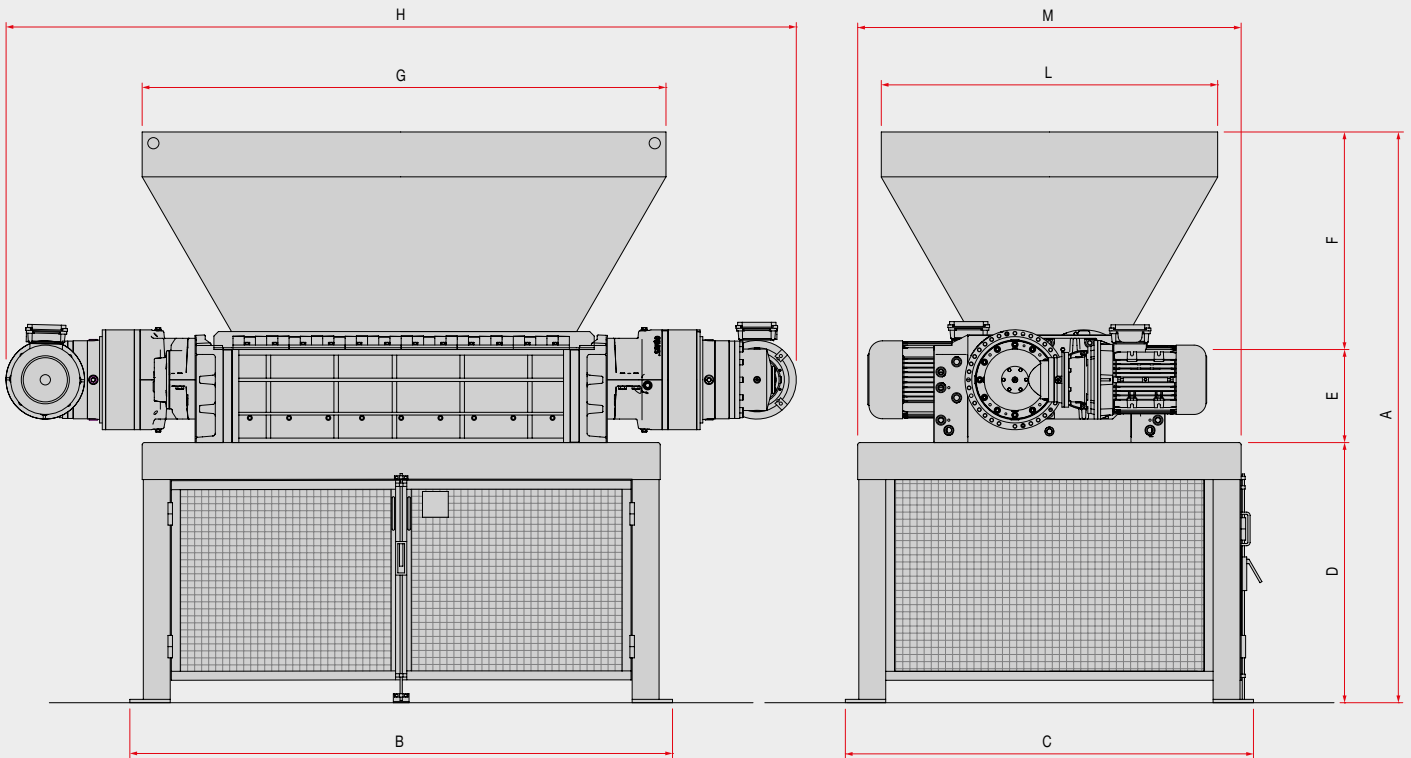

Dimensions - Dimensions

Modèle Model	A mm	B mm	C mm	D mm	E mm	F mm	G mm	H mm	L mm	M mm
2R10/50ER	2545	1920	1820	1160	415	970	1840	3030	1500	1710
2R13/50ER	2545	2170	1820	1160	415	970	2090	3280	1500	1710
2R15/50ER	2545	2420	1820	1160	415	970	2340	3530	1500	1710

Données techniques - Technical data

Modèle Model	Chambre de broyage Shredding chamber	Epaisseur des lames Blades thickness	Puissance Power	Poids Weight
2R10/50ER	1008x850 mm	30 - 50 mm	37 (18,5 +18,5) kW	5400 kg
2R13/50ER	1258x850 mm	30 - 50 mm	37 (18,5 +18,5) kW	6000 kg
2R15/50ER	1508x850 mm	30 - 50 mm	37 (18,5 +18,5) kW	6600 kg

Applications - Applications

	Plastique Plastics	600-1600
	Déchets industriels Industrial scraps/ waste	800-2500
	Pneus de voiture Car tyres	2000-2500
	Déchets urbains solides Municipal solid waste	1000-2500
	Tambours métalliques Metal drums	60-100 pcs/h
Matériaux - Material		kg/h

 **SatrindTech**
Shredding Solutions

SatrindTech Srl Via Monfalcone, 122 - 20004 Arluno (Milano) - Italy
Tel +39 02 90376683 - Fax +39 02 90376721

info@satrindtech.com - www.satrindtech.com

 **ISIGRANTech**

Isigrantech S.A.S. - 59710 Ennevelin (France) - Tel+33.320.231.650

isigrantech@lc-groupe.fr - www.isigrantech.fr

Représentant officiel pour le France de SatrindTech Srl

