

3R320

Broyeur industriel
Industrial shredders

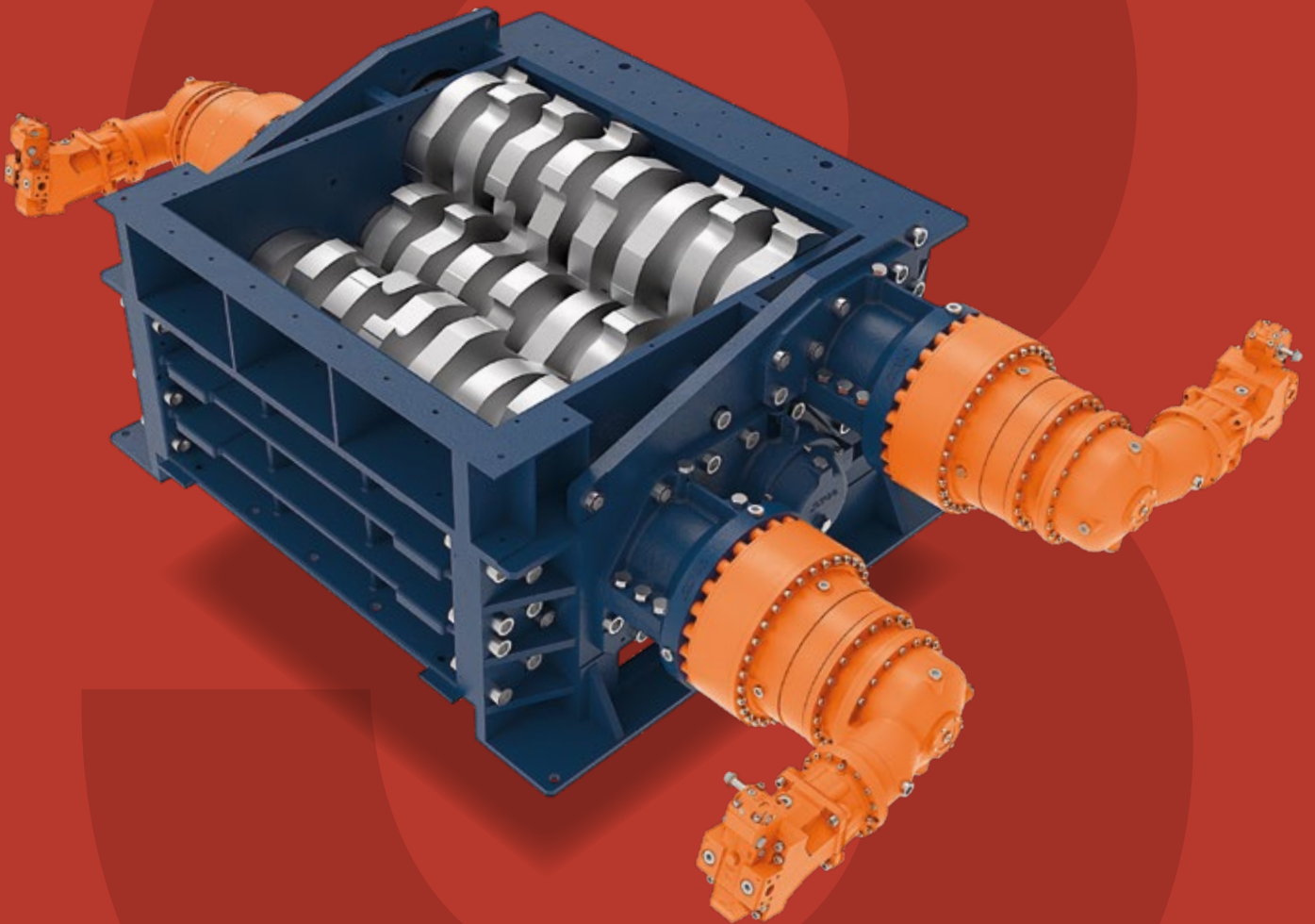

3 arbres / Entraînement hydraulique
3 shaft / Hydraulic drive

235 kW

ISIGRANTech
Partenaire intégrateur pour la France

SatrindTech
Shredding Solutions

3R320

Made in Italy 

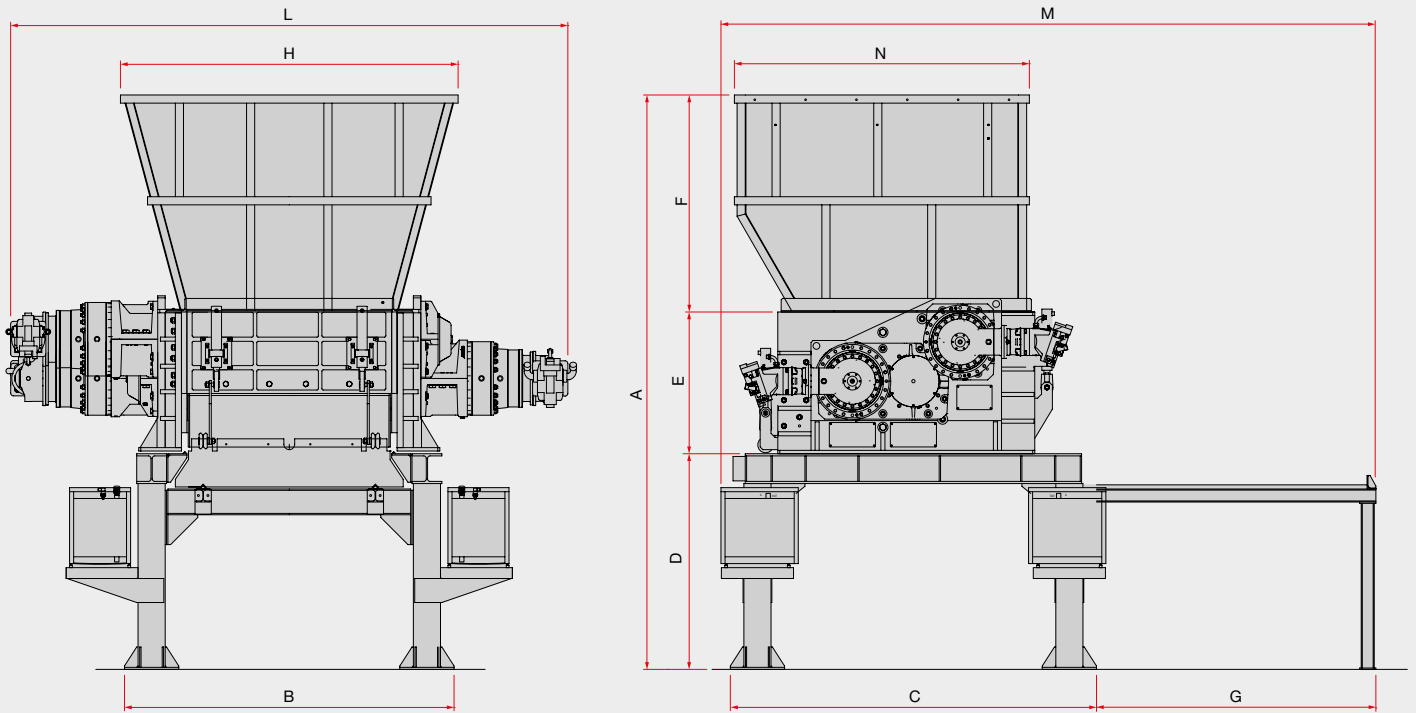

Dimensions - Dimensions

Modèle Model	A mm	B mm	C mm	D mm	E mm	F mm	G mm	H mm	L mm	M mm	N mm
3R15/320	4235	2430	2700	1590	1045	1600	2060	2490	4110	4830	2175
3R20/320	4235	2880	2700	1590	1045	1600	2060	2940	4560	4830	2175

Données techniques- Technical data

Modèle Model	Chambre de broyage Shredding chamber	Epaisseur des lames Blades thickness	Puissance Power	Poids Weight
3R15/320	1500x1250 mm	50 - 75 mm	235 (160+75) kW	16000+1620+2580 kg
3R20/320	1950x1250 mm	50 - 75 mm	235 (160+75) kW	18500+1620+2580 kg

Applications - Applications

 Déchets hospitaliers Hospital waste	2000-6000
 Plastique Plastics	2000-5000
 Déchets industriels Industrial scraps/waste	2000-7000
 Déchets solides urbains Municipal solid waste	3000-10000
 Déchets électroniques WEEE	2500-6000
Matériau - Material	kg/h