

K150M

Broyeur déchiqueteur
Industriel

Industrial shredders



2 arbres/ Entraînement électrique

2 shaft / Electric drive

110 kW

ISIGRANTech

Partenaire intégrateur pour la France

SatrindTech
Shredding Solutions

K150M

Made in Italy 

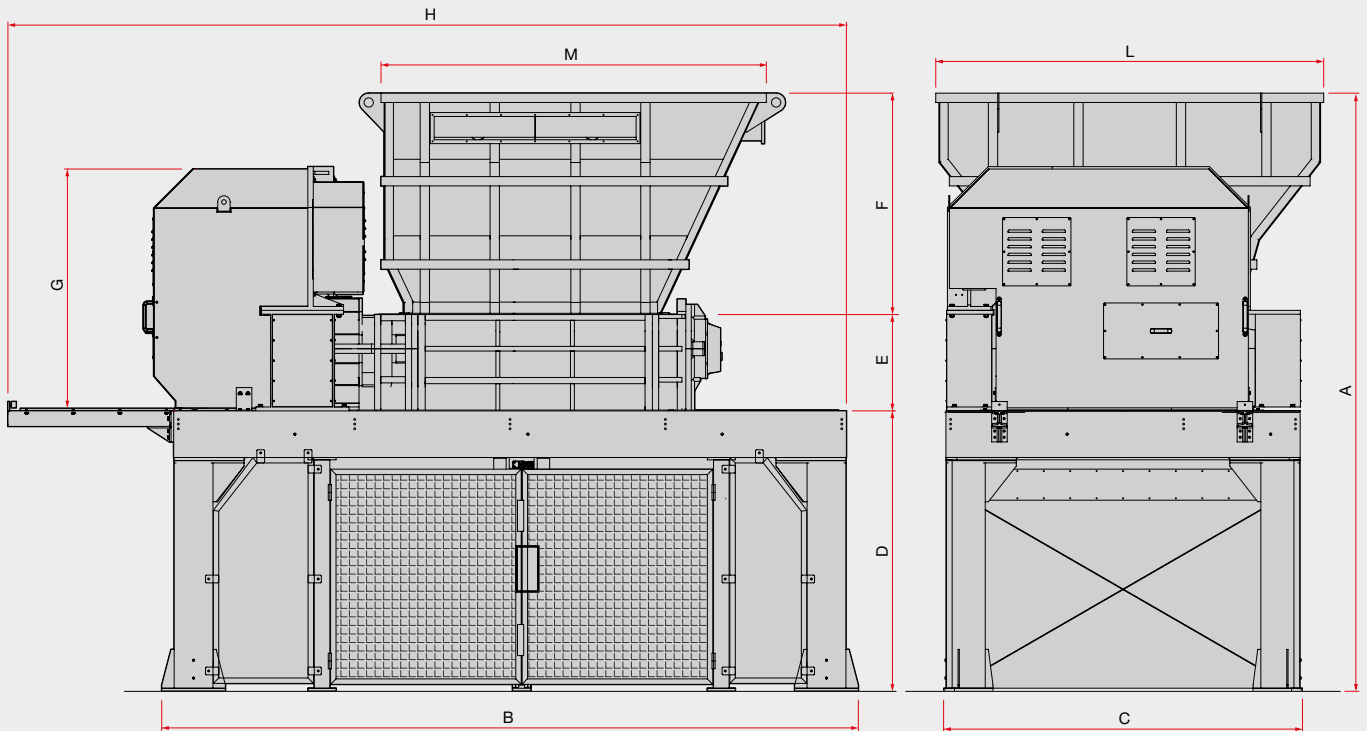





Dimensions - Dimensions

Modèle Model	A mm	B mm	C mm	D mm	E mm	F mm	G mm	H mm	L mm	M mm
K15/150M	3845	4485	2310	1800	620	1425	1560	5400	2500	2480
K20/150M	3845	4985	2310	1800	620	1425	1560	5900	2500	2980

Données techniques - Technical data

Modèle Model	Chambre de broyage Shredding chamber	Epaisseur des lames Blades thickness	Puissance Power	Poids Weight
K15/150M	1510x1100 mm	75 mm	110 kW	18300 kg
K20/150M	2010x1100 mm	75 mm	110 kW	20300 kg

Applications - Applications

	Déchets industriels Industrial scraps/waste	7-12
	Pneus Tyres	8-15
	Déchets solides urbains Municipal solid waste	20-40
	Tambours métalliques Metal drums	240 pcs/h
	Déchets encombrants Bulky waste	6-7
	Matériaux - Material	t/h