

# K30T

Broyeur déchiqueteur  
de déchets

Waste crushers

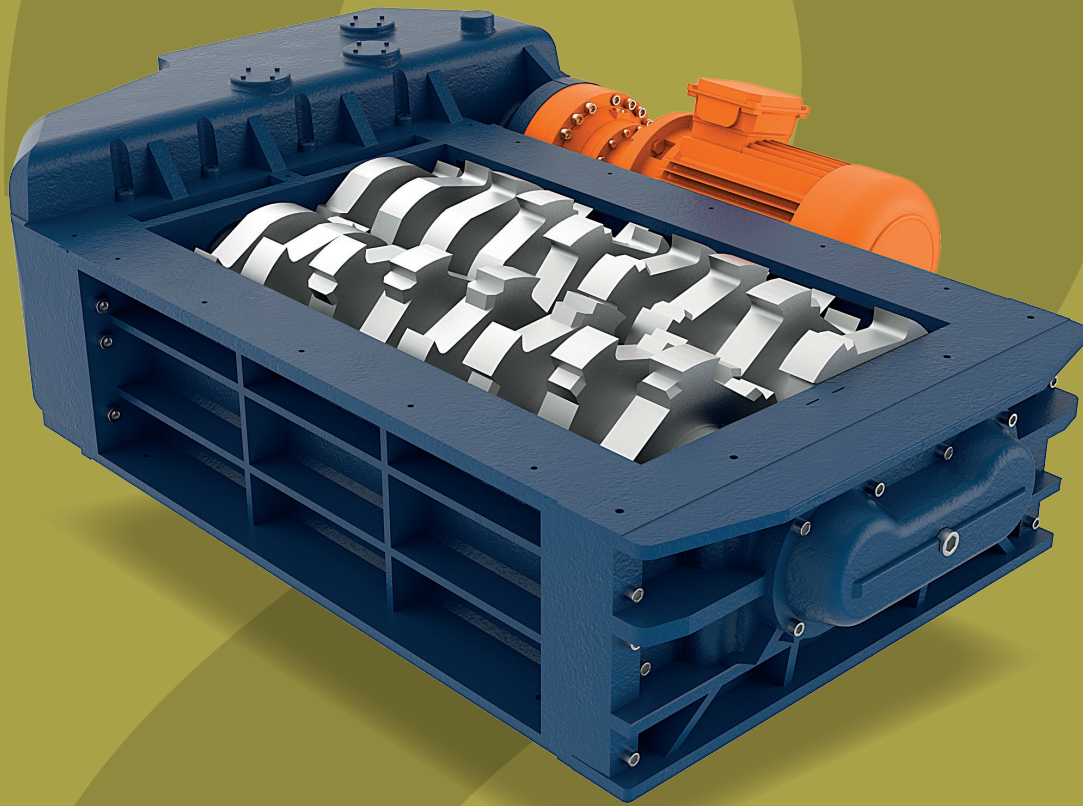

**2 arbres / Entraînement électrique**

2 shaft / Electric drive

**22 kW**

**ISIGRANTech**

Partenaire intégrateur pour la France

 **SatrindTech**  
Shredding Solutions

# K30T

Made in Italy 

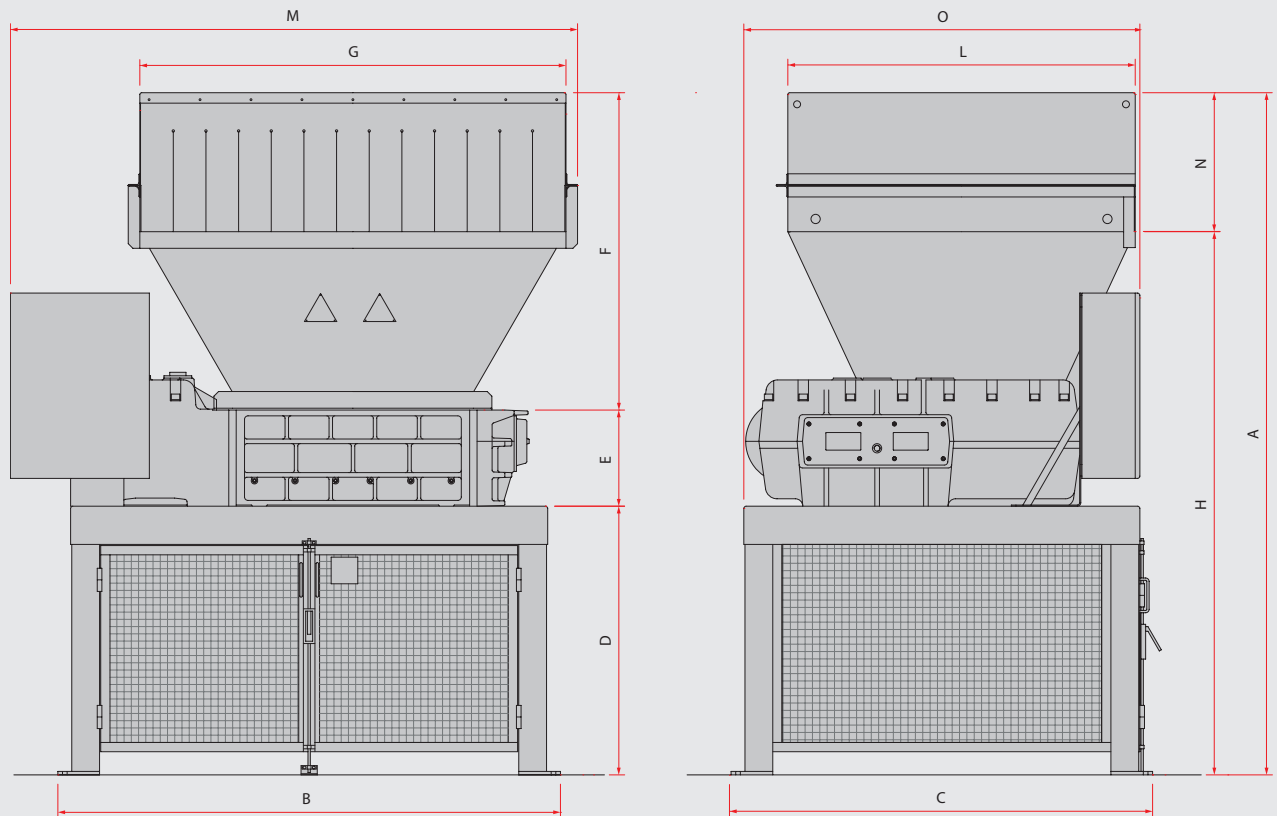

## Dimensions - Dimensions

| Modèle<br>Model | A<br>mm | B<br>mm | C<br>mm | D<br>mm | E<br>mm | F<br>mm | G<br>mm | H<br>mm | L<br>mm | M<br>mm | N<br>mm | O<br>mm |
|-----------------|---------|---------|---------|---------|---------|---------|---------|---------|---------|---------|---------|---------|
| <b>K13/30T</b>  | 2945    | 2420    | 1820    | 1160    | 415     | 1370    | 2090    | 2345    | 1500    | 2700    | 600     | 1710    |

## Données techniques - Technical data

| Modèle<br>Model | Chambre de broyage<br>Shredding chamber | Epaisseur des lames<br>Blades thickness | Puissance<br>Power | Poids<br>Weight |
|-----------------|---|---|--------------------|-----------------|
| <b>K13/30T</b>  | 1258x850 mm                             | 30 mm                                   | 22 kW              | 4400 kg         |

## Applications- Applications

|   |   |             |
|---|---|-------------|
|  | <b>Déchets organiques</b><br>Organic waste              | 3500-5000   |
|  | <b>Bois</b><br>Wood                                     | 2000-3000   |
|  | <b>Déchets solides urbains</b><br>Municipal solid waste | 1500-3000   |
|  | <b>Déchets électroniques</b><br>WEEE                    | 1500-2000   |
|  | <b>Verre</b><br>Glass                                   | 1500-2000   |
| <b>Matériaux - Material</b>   |   | <b>kg/h</b> |