

K50

Broyeur déchiqueteur
Industriel
Industrial shredders

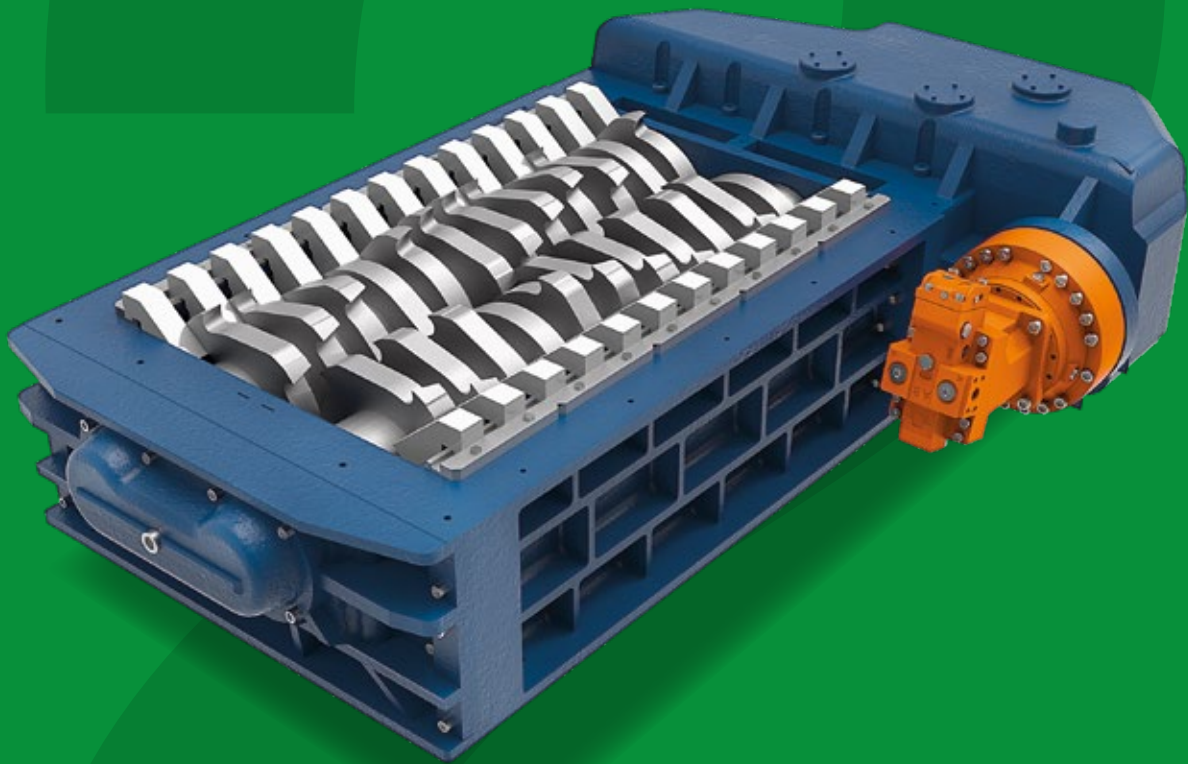

2 arbres / Entraînement hydraulique
2 shaft / Hydraulic drive

37 kW

ISIGRANTech
Partenaire intégrateur pour la France

SatrindTech
Shredding Solutions

K50

Made in Italy 

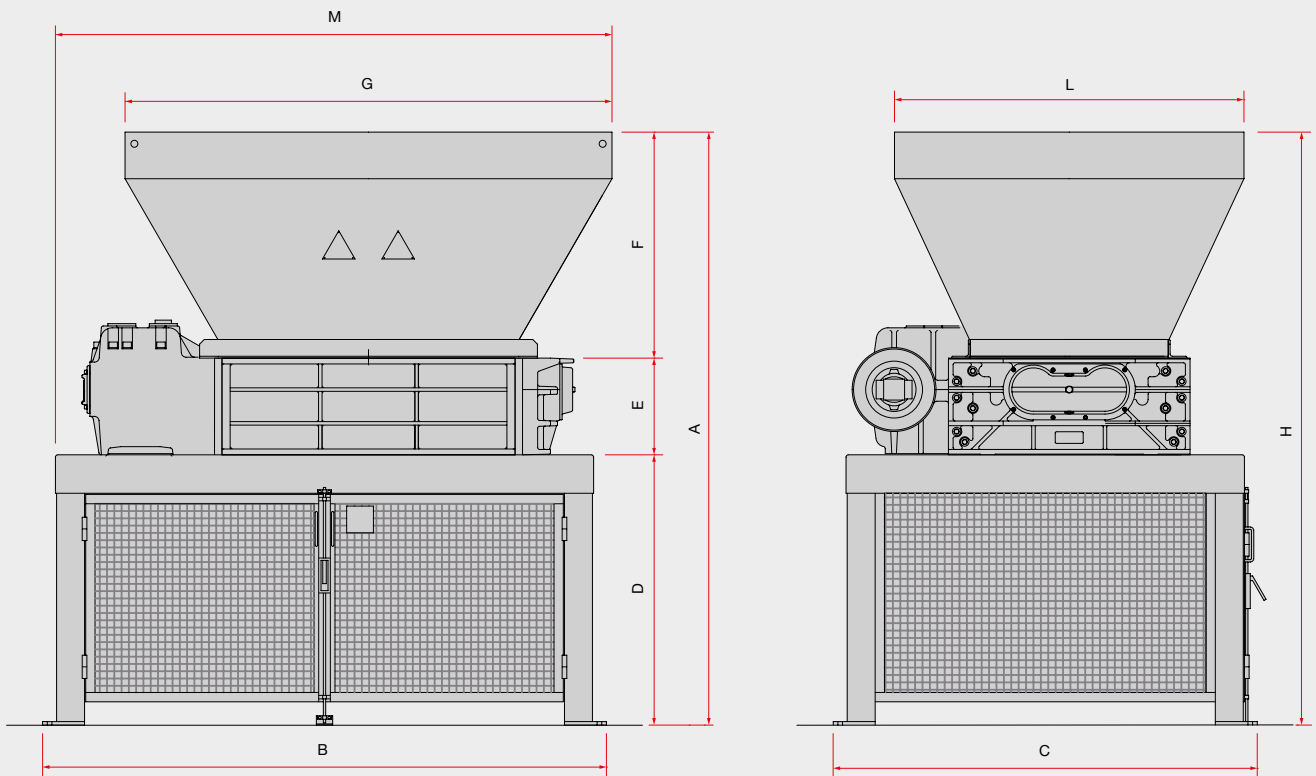

Dimensions - Dimensions

Modèle Model	A mm	B mm	C mm	D mm	E mm	F mm	G mm	H mm	L mm	M mm
K8/50	2945	2070	1820	1160	415	1370	1590	2545	1500	2140
K10/50	2945	2170	1820	1160	415	1370	1840	2545	1500	2365
K13/50	2945	2420	1820	1160	415	1370	2090	2545	1500	2390

Données techniques - Technical data

Modèle Model	Chambre de broyage Shredding chamber	Épaisseurs des lames Blades thickness	Puissance Power	Poids Weight
K8/50	758x850 mm	30 - 50 mm	37 kW	3800+1050 kg
K10/50	1008x850 mm	30 - 50 mm	37 kW	4200+1050 kg
K13/50	1258x850 mm	30 - 50 mm	37 kW	4600+1050 kg

Applications - Applications

	Plastique Plastics	800-2000
	Déchets industriels Industrial scraps/waste	1000-3000
	Pneus de voiture Car tyres	2500-3000
	Déchets urbains solides Municipal solid waste	1500-3000
	Tambours métalliques Metal drums	60-100 pcs/h
Matériaux - Material		kg/h